



SmartPipe+™

3/4" to 2 1/2" Aluminum Compressed Air Piping

Product Catalog

kaeser.com



SmartPipe+™

Compressed Air Piping

KAESER's SmartPipe+ is a modular compressed air distribution system that offers both lower installation costs and lower long term operating costs.

Piping selection directly affects the three key elements of every compressed air system: flow, pressure, and air quality. Poor choices in pipe materials, diameter, and layout cause flow restrictions, often resulting in significant pressure drop. Pressure drop is a leading cause of increased energy consumption and under performing air driven tools and equipment.

Choices in piping also directly impact installation costs. Heavier materials cause fatigue and slow work, especially in overhead installations. The types of fittings used must also be considered. Some connection types cause pressure drop, need special tools, and take more time to install.

SmartPipe+ offers an excellent choice for compressed air and inert gas distribution for pressures up to 232 psig (16 bar) (higher pressures available) in temperatures from -22°F to 248°F (-30°C to 120°C). SmartPipe+ is also ideal for vacuum up to 98.3% (29.5" Hg).





Technical Specifications

SmartPipe+ is designed for use with compressed air, vacuum, and inert gases

Pressure and Temperature Ranges

- Maximum working pressure: 232 psig
- Maximum vacuum: 98.3% (29.5" Hg)
- Maximum working temperature: -22°F to 248°F
- Storage temperature: -40°F to 212°F
- Consult factory for higher pressures or temperatures

Aluminum Pipe Specification

- 6063-T5 aluminum grade
- Extruded pipe conforms to standards EN755.2 and EN755.8
- Smooth bore ID for optimal flow rate performance
- Powder coat in BLUE (RAL5012) with QUALICOAT CERTIFIED lacquer finish exterior
- Consult factory for availability of other colors

Aluminum Fittings Specification

- Connector bodies manufactured in aluminum alloy ASTM B26-356.0
- Nuts are aluminum alloy per ASTM B241-6061 and anodized
- Nut threads meet ANSI B1.20.1 standard
- Fitting bodies are black cataphoresis coated with a minimum thickness of 10 µm

Flexible Hose Specification

- Resistant to mineral and synthetic oils
- Maximum working pressure varies depending on size
- Fire resistance testing conducted per the ISO 8030:2014 standard

Pipe Sizes

Nominal Ø (in.)	Outside Ø (in.)	Outside Ø (mm)	Inside Ø (in.)	Inside Ø (mm)	Wall Thickness (in.)	Wall Thickness (mm)
3/4	3/4	20.1	11/16	18	3/64	1.0
1	1	25.1	7/8	22.8	3/64	1.1
1-1/4	1-1/4	32.1	1-3/16	29.6	3/64	1.2
1-1/2	1-9/16	40.1	1-1/2	37.4	3/64	1.3
2	2	50.1	1-7/8	47	1/16	1.5
2-1/2	2-1/2	63.1	2-5/16	59.4	5/64	1.8

Specifications subject to change without notice.

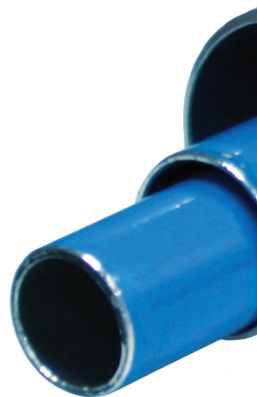

Certification

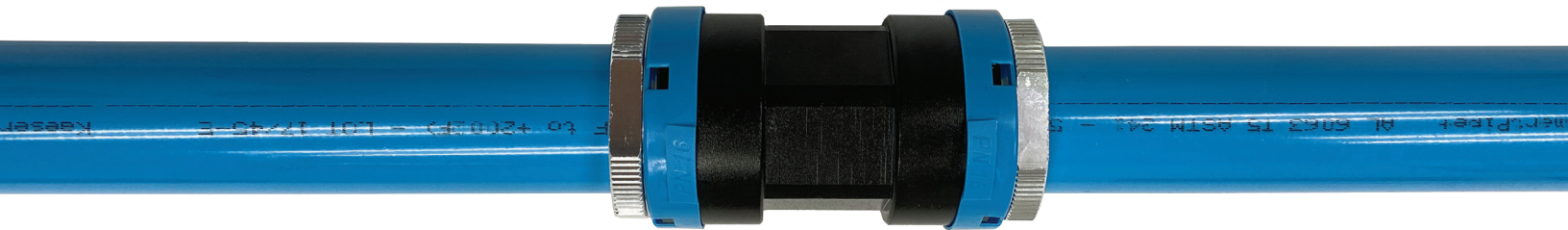

- SmartPipe+ meets the requirement of ASME B31.1 which stipulates the minimum requirements for the design, materials, fabrication, installation, test, and inspection of power and auxiliary piping systems for industrial plants. SmartPipe+ also meets ASME B31.3 and B31.9.
- SmartPipe+ also conforms to European standard 2014/68/EU regarding equipment under pressure.
- KAESER warrants its SmartPipe+ products to be free of defects in material and workmanship for a period of ten (10) years from the date of purchase of the products.
- QUALICOAT certification is a guarantee of the quality of the lacquer finish applied to the SmartPipe+ aluminum pipe.

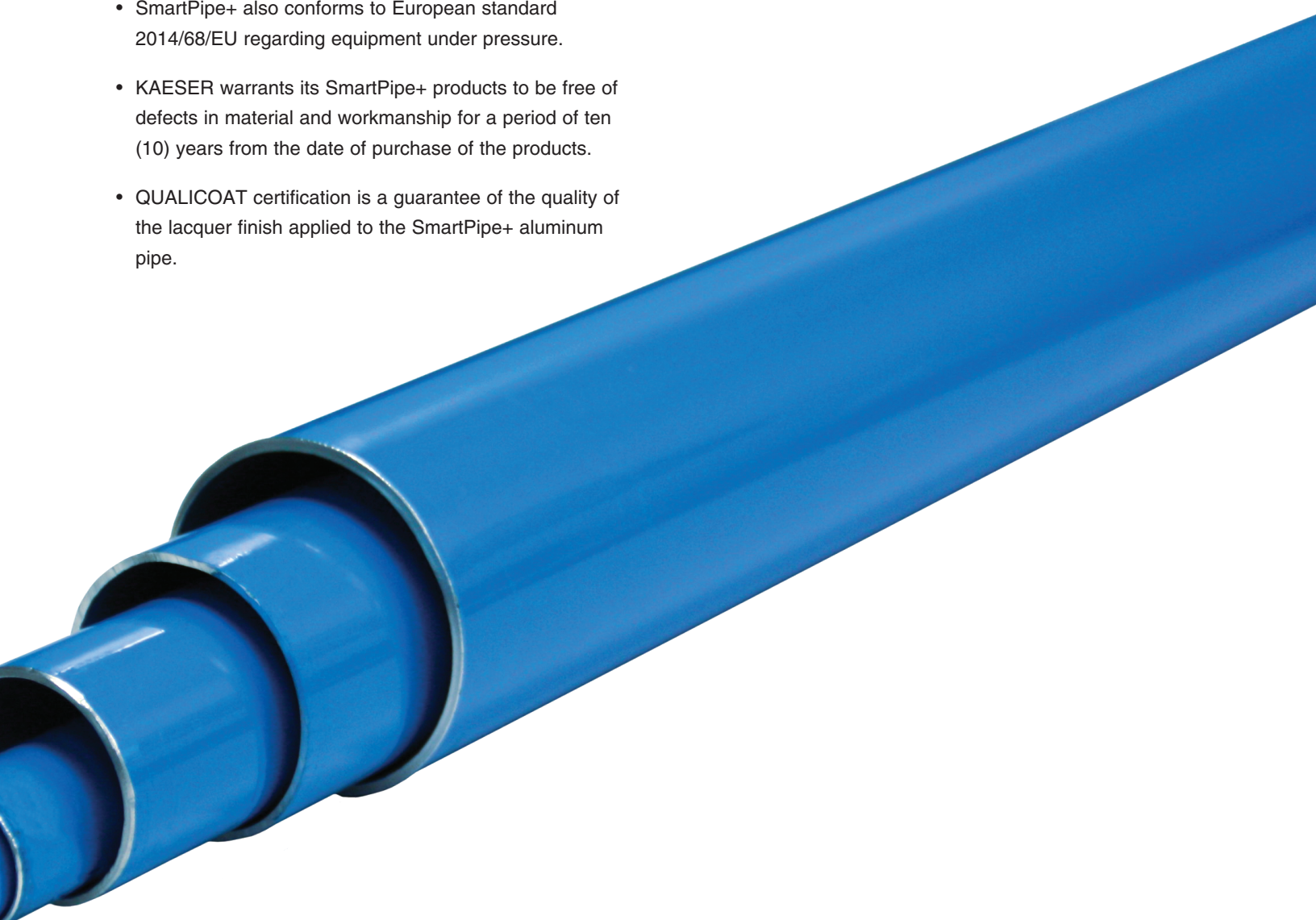

Specifications subject to change without notice.

Sizing

Select the SmartPipe+ diameter for your application based on required flow and allowable pressure drop

In the charts below, pipe size (in mm) is recommended assuming 100 psig and target pressure drop below 5.5 psi

For Branch or Linear Distribution Networks

Equivalent Length (feet)											
Flow (cfm)	50	150	300	400	500	1000	2000	3000	4000	5000	
10	20	20	20	20	20	20	20	25	25	25	
25					25	25	32	32	32	40	
50	25	25	25	32	32	32	40	40	40	50	
75			32								40
100	32	32	32	40	40	40	50	63	63	63	
150	40	40	40				50				63
250	50	50	50	50	50	63	63				
500	63	63	63	63	63						
750											
900											
1000											

Note: For flows above the range shown, see SmartPipeXL.

For Looped Distribution Networks

Equivalent Length (feet)						
Flow (cfm)	500	1000	2000	3000	4000	5000
10	20	20	20	20	20	20
25		25	25	25	32	32
50	25	32	32	40	40	40
75			40			
100	32	40	40	50	50	50
150	40					
250	40	50	63	63	63	63
350	50	63				
500	63					
750	63					

Note: For flows above the range shown, see SmartPipeXL.

Specifications subject to change without notice.

Example

An application requires a KAESER BSD 50 @ 110 psig with the appropriate air treatment. The application cannot tolerate a pressure drop of more than 5.5 psi in the main header when the main distribution header pressure is 100 psig.

Note: the main distribution header is looped.

KAESER BSD 50 @ 110 psig = 232 cfm (FAD)

Main distribution pipe length (including equivalent length for all fittings) = 1000 ft.

Main header pressure = 100 psig

If the distribution network is a branch or linear, use 63 mm diameter pipe.

For a looped distribution network, use 50 mm diameter pipe.

Note:

- 1) To calculate the pressure drop at the point of use, add up the equivalent pipe length for all connectors and air treatment equipment.
- 2) It is important to keep in mind the maximum pipe velocity for each section of the compressed air distribution system.
 - a. Not to exceed 15 ft./s (5 m/s) pipe velocity in the compressor room
 - b. Not to exceed 30 ft./s (10 m/s) pipe velocity in main header
 - c. Not to exceed 45 ft./s (15 m/s) pipe velocity in the branch lines
- 3) Consider up sizing to allow for future increases in system capacity.



Aluminum Pipe

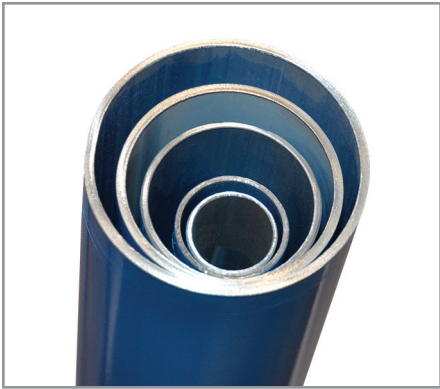

Part No.	ØD (mm)	L	S	Weight
AN8290002010	20	19'	3/64	2.52
AN8290002510	25		3/64	3.17
AN8290003210	32		3/64	4.37
AN8290004010	40		3/64	5.68
AN8290005010	50		1/16	7.67
AN8290006310	63		5/64	13.49

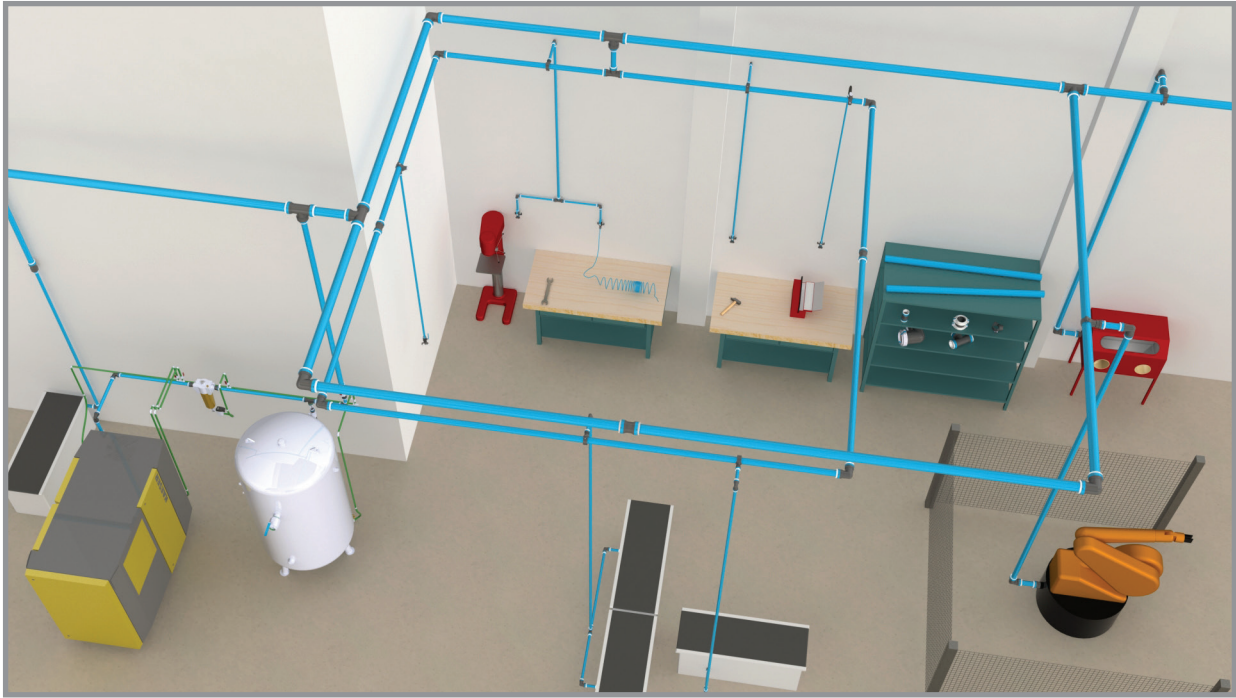
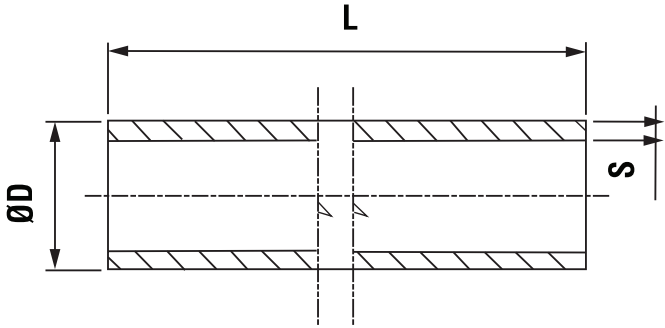

Dimensions in inches (in.) and weight in pounds (lbs.) unless otherwise noted. For larger piping and fittings, see SmartPipeXL. For installation instructions, see SmartPipe+ Service Manual. **Specifications subject to change without notice.**

Equal Union



Part No.	ØD (mm)	A	E	L	S	Weight
AN82010020	20	2-3/4	1-7/16	1-3/8	1-1/8	0.17
AN82010025	25	2-15/16	1-5/8	1-7/16	1-7/16	0.22
AN82010032	32	3-11/16	2	1-13/16	1-11/16	0.38
AN82010040	40	4-5/8	2-1/2	2-1/4	2-1/16	0.82
AN82010050	50	5-7/16	3-1/16	2-11/16	2-5/8	1.44
AN82010063	63	6-13/16	3-3/4	3-1/4	3-1/4	2.59

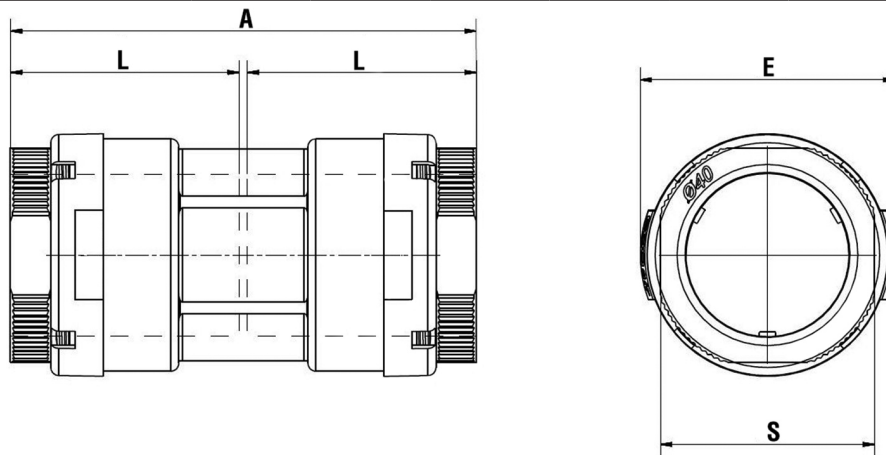

Sliding Coupling

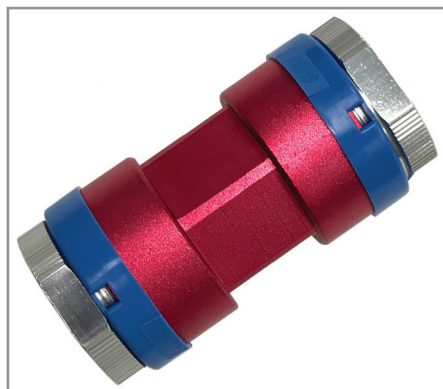

Part No.	ØD (mm)	A	E	S	Weight
AN82012020	20	2-3/4	1-7/16	1-1/8	0.18
AN82012025	25	2-15/16	1-5/8	1-7/16	0.22
AN82012032	32	3-11/16	2	1-11/16	0.38
AN82012040	40	4-5/8	2-1/2	2-1/16	0.74
AN82012050	50	5-7/16	3-1/16	2-5/8	1.46
AN82012063	63	6-13/16	3-3/4	3-1/4	2.42

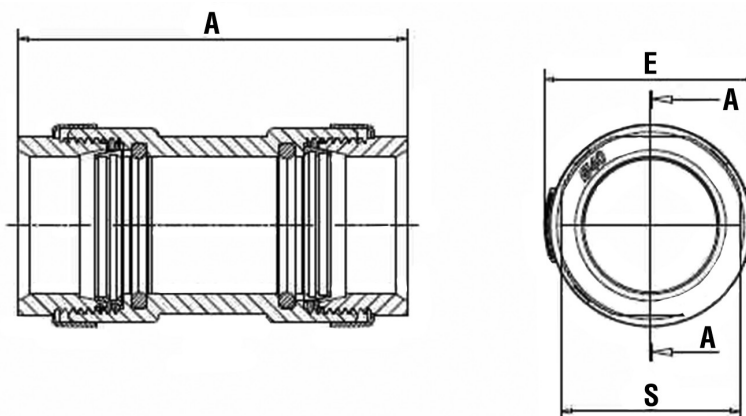

Dimensions in inches (in.) and weight in pounds (lbs.) unless otherwise noted. For larger piping and fittings, see SmartPipeXL. For installation instructions, see SmartPipe+ Service Manual. **Specifications subject to change without notice.**

Male Adapter



Part No.	ØD x NPT (mm x in.)	A	E	L	S	Weight
AN8202002004	20 x 1/2	1-15/16	1-7/16	1-3/8	1-1/8	0.10
AN8202002006	20 x 3/4	2	1-7/16	1-3/8	1-1/8	0.11
AN8202002549	25 x 1/2	2-1/8	1-5/8	1-7/16	1-7/16	0.12
AN8202002506	25 x 3/4	2-3/16	1-5/8	1-7/16	1-7/16	0.13
AN8202002508	25 x 1	2-3/8	1-5/8	1-7/16	1-7/16	0.19
AN8202003208	32 x 1	2-11/16	2	1-13/16	1-11/16	0.24
AN8202003210	32 x 1-1/4	2-3/4	2	1-13/16	1-11/16	0.28
AN8202004010	40 x 1-1/4	3-3/16	2-1/2	2-1/4	2-1/16	0.41
AN8202004012	40 x 1-1/2	3-3/16	2-1/2	2-1/4	2-1/16	0.44
AN8202005012	50 x 1-1/2	3-5/8	3-1/16	2-11/16	2-5/8	0.70
AN8202005016	50 x 2	3-3/4	3-1/16	2-11/16	2-5/8	0.73
AN8202006316	63 x 2	4-11/16	3-3/4	3-1/4	3-1/4	1.17
AN8202006320	63 x 2-1/2	4-3/4	3-3/4	3-1/4	3-1/4	1.44

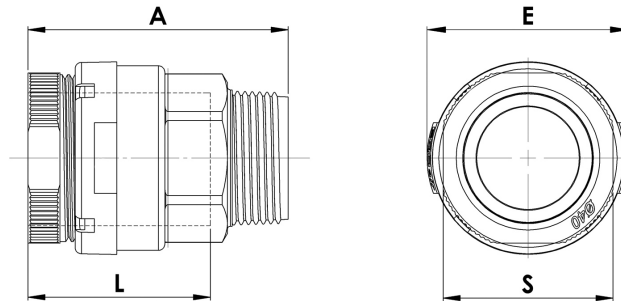

Female Adapter



Part No.	ØD x NPT (mm x in.)	A	E	L	S	Weight
AN8203002004	20 x 1/2	2-3/16	1-7/16	1-3/8	1-1/8	0.12
AN8203002506	25 x 3/4	2-1/4	1-5/8	1-7/16	1-7/16	0.16
AN8203003208	32 x 1	2-11/16	2	1-13/16	1-11/16	0.26
AN8203004010	40 x 1-1/4	3-1/8	2-1/2	2-1/4	2-1/16	0.5
AN8203005012	50 x 1-1/2	3-3/4	3-1/16	2-5/8	2-5/8	0.84
AN8203006316	63 x 2	4-3/4	3-3/4	3-1/4	3-1/4	1.7

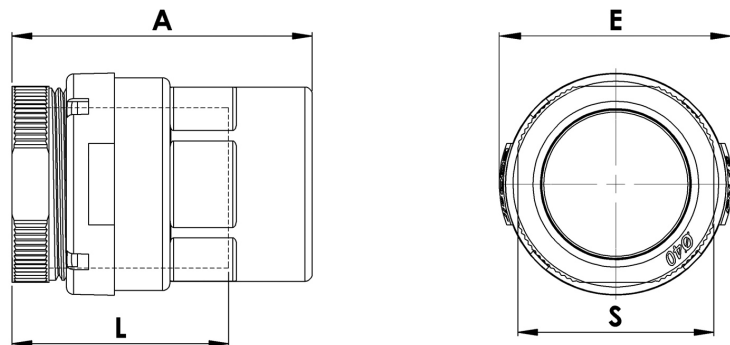

Dimensions in inches (in.) and weight in pounds (lbs.) unless otherwise noted. For larger piping and fittings, see SmartPipeXL. For installation instructions, see SmartPipe+ Service Manual. **Specifications subject to change without notice.**

Equal Tee



Part No.	ØD (mm)	A	B	E	L	S	Weight
AN82040020	20	4	2-11/16	1-7/16	1-3/8	1-1/8	0.27
AN82040025	25	4-3/8	2-15/16	1-5/8	1-7/16	1-7/16	0.36
AN82040032	32	5-3/8	3-11/16	2	1-13/16	1-11/16	0.64
AN82040040	40	6-3/8	4-5/16	2-1/2	2-1/4	2-1/16	1.04
AN82040050	50	8-1/8	5-9/16	3-1/16	2-11/16	2-5/8	2.04
AN82040063	63	9-1/16	6-5/16	3-3/4	3-1/4	3-1/4	3.06

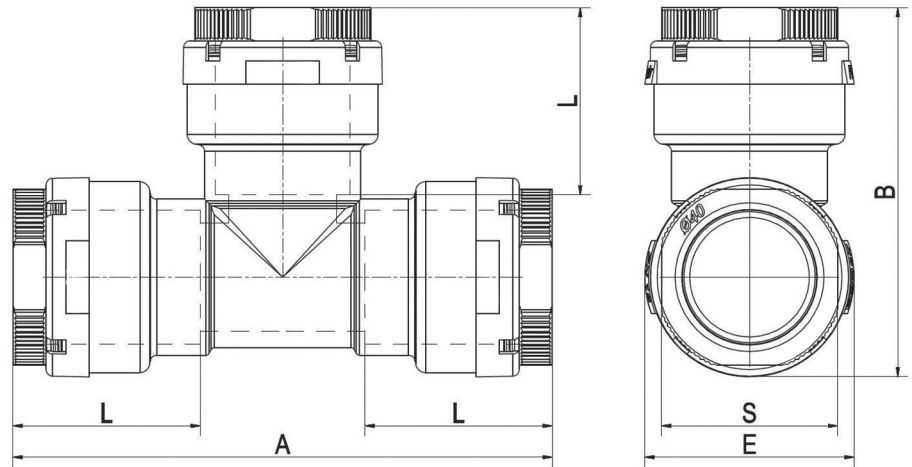

Female Threaded Equal Tee



Part No.	ØD x NPT (mm x)	A	B	E	L	S	Weight
AN8204102004	20 x 1/2	4	1-7/8	1-7/16	1-3/8	1-1/8	0.23
AN8204102506	25 x 3/4	4-3/8	2-1/4	1-5/8	1-7/16	1-7/16	0.30
AN8204103208	32 x 1	5-3/8	2-3/4	2	1-13/16	1-11/16	0.49
AN8204104010	40 x 1-1/4	6-3/8	3-1/16	2-1/2	2-1/4	2-1/16	0.88
AN8204105012	50 x 1-1/2	8-1/8	3-3/4	3-1/16	2-11/16	2-5/8	1.78
AN8204106316	63 x 2	9-1/16	4-1/2	3-3/4	3-1/4	3-1/4	2.91

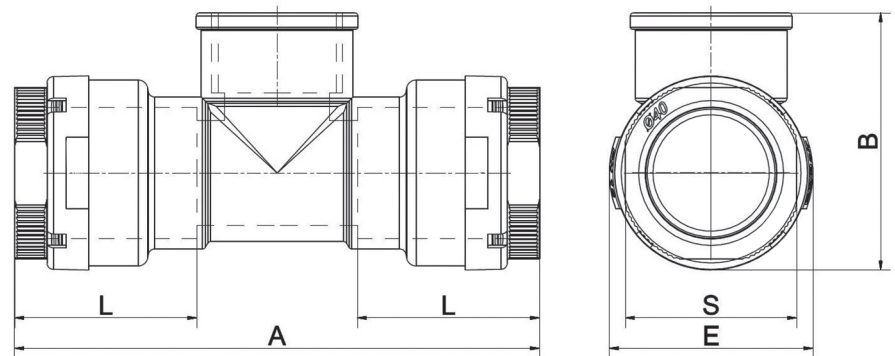

Dimensions in inches (in.) and weight in pounds (lbs.) unless otherwise noted. For larger piping and fittings, see SmartPipeXL. For installation instructions, see SmartPipe+ Service Manual. **Specifications subject to change without notice.**

Equal 90° Elbow



Part No.	ØD (mm)	A	E	L	S	Weight
AN82050020	20	2-3/8	1-7/16	1-3/8	1-1/8	0.19
AN82050025	25	3	1-5/8	1-7/16	1-7/16	0.25
AN82050032	32	3-9/16	2	1-13/16	1-11/16	0.45
AN82050040	40	4-7/16	2-1/2	2-1/4	2-1/16	1.22
AN82050050	50	5-5/8	3-1/16	2-11/16	2-5/8	1.47
AN82050063	63	6-5/8	3-3/4	3-1/4	3-1/4	2.41

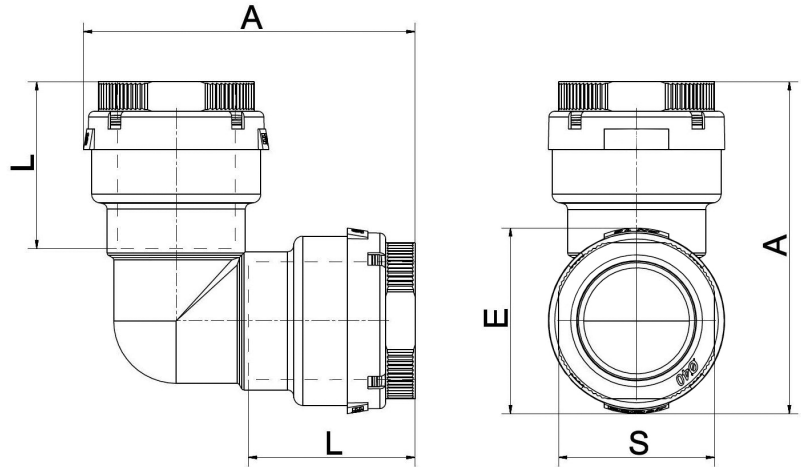

Male Threaded 90° Elbow



Part No.	ØD x NPT (mm x)	A	B	E	L	S	Weight
AN8205202004	20 x 1/2	2-7/16	1-7/8	1-7/16	1-3/8	1-1/8	0.12
AN8205202549	25 x 1/2		2-1/4	1-5/8	1-7/16	1-7/16	0.22
AN8205202506	25 x 3/4	2-5/8	2-1/4	1-5/8	1-7/16	1-7/16	0.22
AN8205203208	32 x 1	3-7/16	2-3/4	2			0.31
AN8205204010	40 x 1-1/4	4-1/8	3-1/16	2-1/2	2-1/4	2-1/16	0.60
AN8205204012	40 x 1-1/2	4-3/16	3-3/4	2-1/2	2-1/4	2-1/16	0.60
AN8205204016	40 x 2	4-3/8	4-3/16	2-1/2	2-1/4	2-1/16	0.68
AN8205205012	50 x 1-1/2		3-3/4	3-1/16		2-5/8	1.04
AN8205206316	63 x 2	6-1/4	4-1/2	3-3/4	3-1/4	3-1/4	2.04

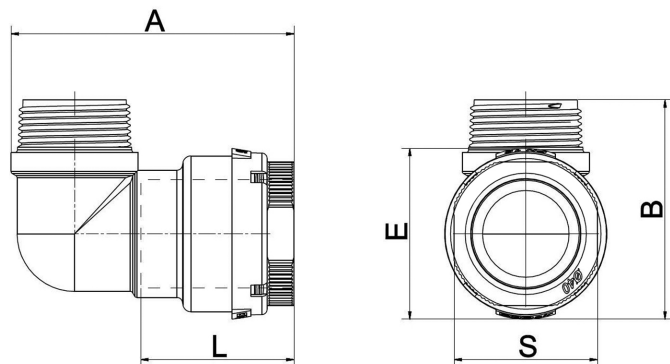

Dimensions in inches (in.) and weight in pounds (lbs.) unless otherwise noted. For larger piping and fittings, see SmartPipeXL. For installation instructions, see SmartPipe+ Service Manual. **Specifications subject to change without notice.**

Equal 45° Elbow



Part No.	ØD (mm)	A	B	E	L	S	Weight
AN82053020	20	3-3/8	2-5/16	1-7/16	1-3/8	1-1/8	0.22
AN82053025	25	3-3/4	2-11/16	1-5/8	1-7/16	1-7/16	0.25
AN82053032	32	4-11/16	3-5/16	2	1-13/16	1-11/16	0.45
AN82053040	40	5-9/16	4	2-1/2	2-1/4	2-1/16	0.82
AN82053050	50	6-3/4	4-7/8	3-1/16	2-11/16	2-5/8	1.60
AN82053063	63	8-1/8	5-15/16	3-3/4	3-1/4	3-1/4	2.74

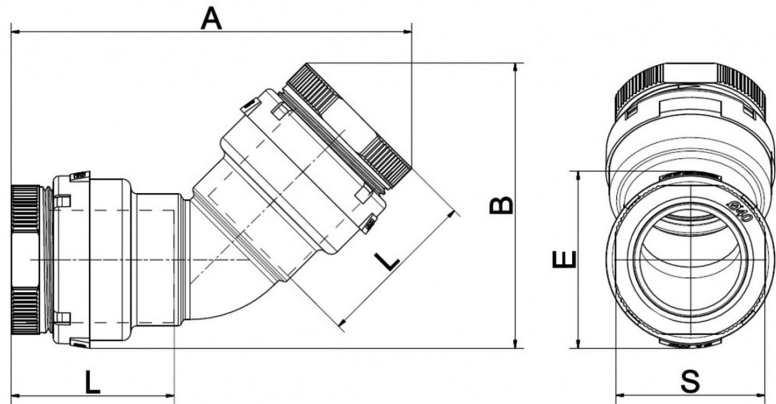

Plug-in Reducer



Part No.	ØD x ØD2 (mm)	A	E	L	S	Weight
AN8202502502	25 x 20	1-13/16	1-5/16	1-3/8	1-1/8	0.12
AN8202503202	32 x 25	2-1/16	1-5/8	1-7/16	1-7/16	0.18
AN8202504020	40 x 20	2-5/16	2-1/16	1-3/8	1-1/8	0.34
AN8202504002	40 x 25	2-3/8	2-1/16	1-7/16	1-7/16	0.39
AN8202504032	40 x 32	2-1/8	2-1/16	1-7/16	1-7/16	0.26
AN8202505004	50 x 40	2-7/8	2-1/4	2-1/4	2-1/16	0.57
AN8202506304	63 x 40	3-3/8	3-1/8	2-1/4	2-1/16	0.91
AN8202506305	63 x 50	3-5/16	2-11/16	2-11/16	2-5/8	1.03

Note: Requires additional ØD fitting. Remove existing nut and clamping ring from existing fitting, then thread ØD into fitting.

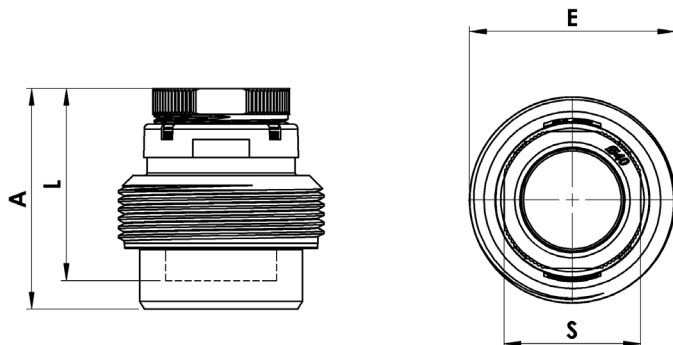

Dimensions in inches (in.) and weight in pounds (lbs.) unless otherwise noted. For larger piping and fittings, see SmartPipeXL. For installation instructions, see SmartPipe+ Service Manual. **Specifications subject to change without notice.**

Male Threaded Connector



Part No.	ØD (mm)	NPT (in.)	A	B	E	Weight
AN8986702049	20	1/2	1-13/16	1-1/16	1-1/8	0.06
AN8986702569	25	3/4	1-15/16	1-1/4	1-5/16	0.10
AN8986703208	32	1	2-1/2	1-1/2	1-5/8	0.23
AN8986704009	40	1-1-4	2-15/16	1-3/4	2-1/16	0.38
AN8986705029	50	1-1/2	3-7/16	2-1/16	2-9/16	0.66
AN8986706369	63	2	4-5/16	2-5/8	3-1/8	1.06

Will require separate SmartPipe+ fitting

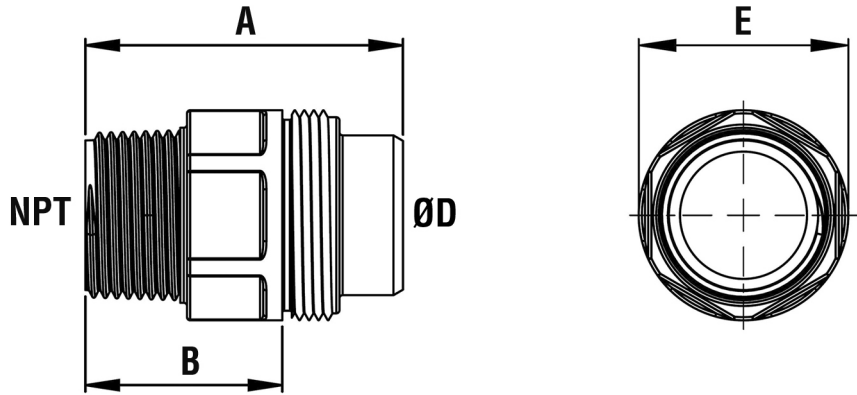

Female Threaded Connector



Part No.	ØD (mm)	NPT (in.)	A	B	E	Weight
AN8986902049	20	1/2	1-9/16	13/16	1-1/8	0.06
AN8986902569	25	3/4	1-5/8	7/8	1-5/16	0.08
AN8986903208	32	1	2-3/16	1-3/16	1-5/8	0.25
AN8986904009	40	1-1-4	2-3/8	1-3/16	2-1/16	0.30
AN8986905029	50	1-1/2	2-7/8	1-1/2	2-9/16	0.66
AN8986906369	63	2	3-5/16	1-5/8	3-1/8	1.06

Will require separate SmartPipe+ fitting

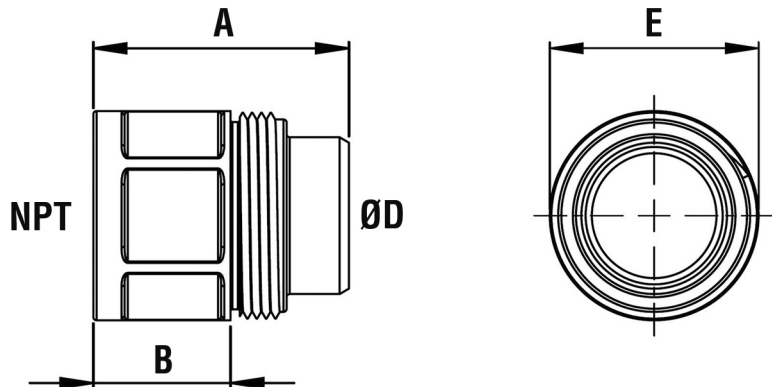

Dimensions in inches (in.) and weight in pounds (lbs.) unless otherwise noted. For larger piping and fittings, see SmartPipeXL. For installation instructions, see SmartPipe+ Service Manual. **Specifications subject to change without notice.**

Fixing Clips

Part No.	ØD (mm)	C	H	L	A	B	Weight
ANK1022	20	3/8"-16	15/16	1-15/16	1-3/16	1-3/16	0.04
ANK2022	25		15/16	2-1/8	1-3/16	1-1/2	0.06
ANK4022	40		1-7/8	3-7/8	1-9/16	2-1/4	0.16
ANK5022	50		1-3/4	4-1/4	1-1/2	2-13/16	0.22
ANK6622	63		1-5/16	4-9/16	1-1/2	3-9/16	0.26

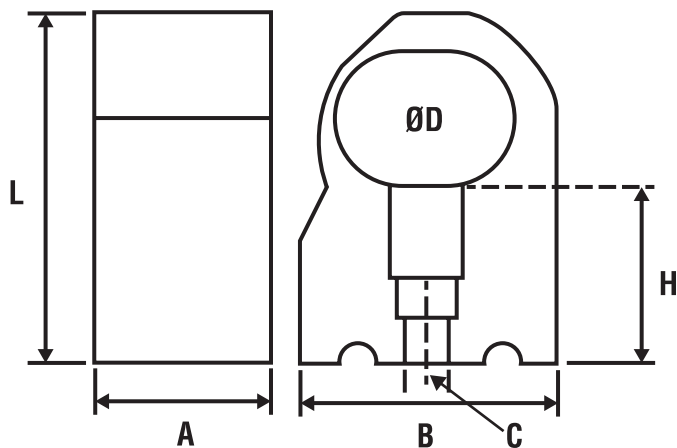

Spacer for Fixing Clips



Part No.	L	W	H	Weight
ANK0027	1-7/8	1-3/16	1-5/16	0.04

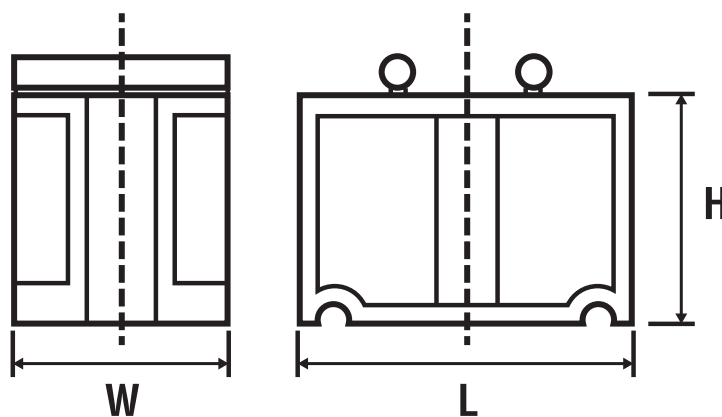

For 20 and 25 mm fixing clips only. Spacer puts the 20 mm and 25 mm fixing clips on the same center line as 40, 50, and 63 mm clips.

Dimensions in inches (in.) and weight in pounds (lbs.) unless otherwise noted. For larger piping and fittings, see SmartPipeXL. For installation instructions, see SmartPipe+ Service Manual. **Specifications subject to change without notice.**

Rubber Lined Bracket 3/8"-16 UNC Connection



Part No.	ØD (mm)	Weight
AN89804020	20	0.13
AN89804025	25	0.13
AN89801032	32	0.13
AN89804040	40	0.17
AN89804050	50	0.20
AN89804063	63	0.22

Rubber Lined Bracket with Wall Anchor



Part No.	ØD (mm)	Weight
AN89805020	20	0.22
AN89805025	25	0.23
AN89800032	32	0.17
AN89805040	40	0.27
AN89805050	50	0.29
AN89805063	63	0.33

Mini Bracket

Part No.	ØD x NPT (mm x in.)	A	A1	A2	B	B1	B2	C	Weight
AN8983502504	25 x 1/2	2-7/16	1	1-7/16	2	11/16	1-5/16	1-5/16	0.16
AN8983503204	32 x 1/2	2-15/16	1-1/4	1-11/16	2-1/4	7/8	1-7/16	1-5/16	0.20
AN8983504004	40 x 1/2	3-9/16	1-5/8	1-15/16	2-3/4	1-1/16	1-11/16	1-7/8	0.36
AN8983504069	40 x 3/4	3-9/16	1-5/8	1-15/16	2-3/4	1-1/16	1-11/16	1-7/8	0.32
AN8983505006	50 x 3/4	4	1-13/16	2-3/16	3-5/16	1-1/4	2-1/16	1-7/8	0.45
AN8983505049	50 x 1/2	4	1-13/16	2-3/16	3-5/16	1-1/4	2-1/16	1-7/8	0.44
AN8983505089	50 x 1	4	1-13/16	2-3/16	3-5/16	1-1/4	2-1/16	1-7/8	0.40
AN8983506306	63 x 3/4	4-13/16	2-5/16	2-1/2	3-7/8	1-9/16	2-5/16	2-1/4	0.78
AN8983563049	63 x 1/2	4-13/16	2-5/16	2-1/2	3-7/8	1-9/16	2-5/16	2-1/4	0.78
AN8983563089	63 x 1	4-13/16	2-5/16	2-1/2	3-7/8	1-9/16	2-5/16	2-1/4	0.70

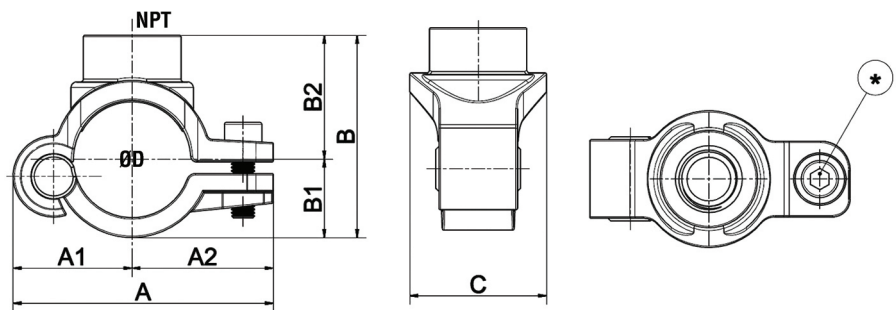

Note: Requires hole saw bit to drill pipe. 1/2" = 14 mm hole saw drill bit (ANK0043). 3/4" = 19 mm hole saw drill bit (ANK0143). 1" = 24 mm hole saw bit, includes Arbor and Pilot, (ANK0342). ANK0243 Drill arbor and pilot bit also required

Dimensions in inches (in.) and weight in pounds (lbs.) unless otherwise noted. For larger piping and fittings, see SmartPipeXL. For installation instructions, see SmartPipe+ Service Manual. **Specifications subject to change without notice.**

Wall Manifold

Part No.	NPT	Fig.	A	B	C	E	F	G	H	I	Wt.
AN8984406904	3/4 x 1/2	1	2	2-3/16	2-1/2	1	1/2 NPT	3/4 NPT	1/4	1	0.4
AN8984706904		2	6-1/16								1.4

Fig. 1

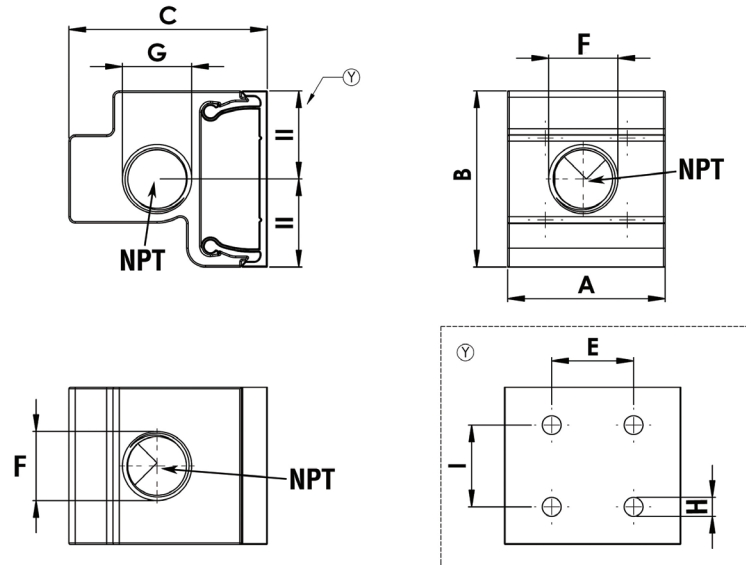
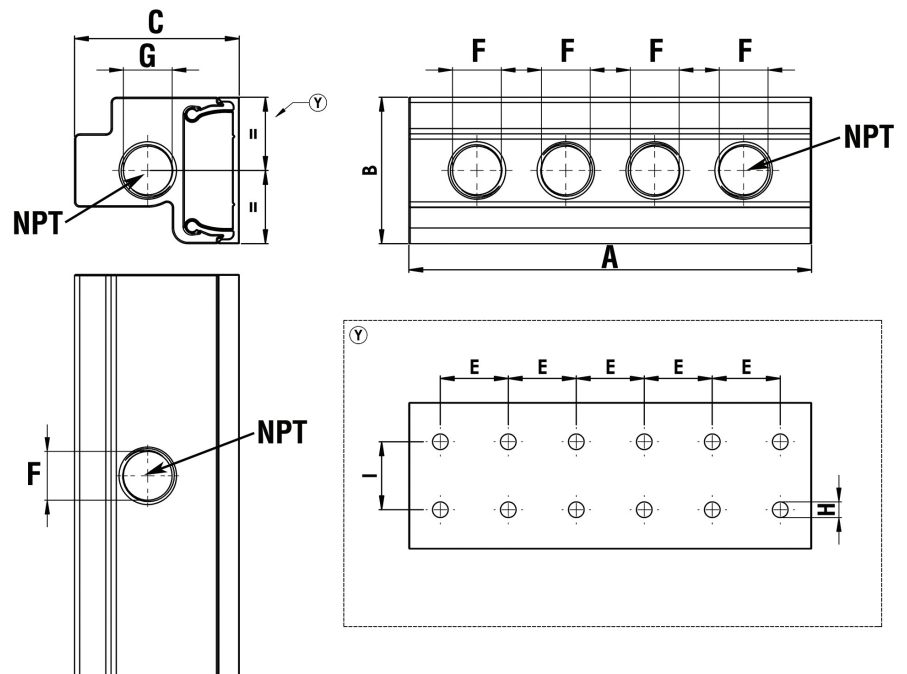

Fig. 2



MOUNTING HARDWARE NOT INCLUDED. Manifold ships as shown without plugs.

Dimensions in inches (in.) and weight in pounds (lbs.) unless otherwise noted. For larger piping and fittings, see SmartPipeXL. For installation instructions, see SmartPipe+ Service Manual. **Specifications subject to change without notice.**

Quick Reducing Bracket

Part No.	ØD x ØD2 (mm)	A	A1	A2	B	B1	B2	C	S	Weight
AN8983002502	25 x 20	4-7/16	3	1-7/16	2-3/4	2-1/16	11/16	1-5/16	1-1/8	0.36
AN8983003202	32 x 20	4-15/16	3-5/16	1-11/16	3-3/16	2-5/16	7/8	1-5/16	1-1/8	0.41
AN8983004002	40 x 20	5-9/16	3-11/16	1-7/8	3-15/16	2-7/8	1-1/16	1-1/2	1-1/8	0.77
AN8983004025	40 x 25	5-5/8	3-3/4	1-7/8	3-15/16	2-7/8	1-1/16	1-1/2	1-7/16	0.71
AN8983005020	50 x 20	5-15/16	3-3/4	2-3/16	4-7/16	3-3/16	1-1/4	1-1/2	1-1/8	0.86
AN8983005002	50 x 25	5-15/16	3-3/4	2-3/16	4-7/16	3-3/16	1-1/4	1-1/2	1-7/16	1.26
AN8983006320	63 x 20	6-3/4	4-1/4	2-1/2	5-3/16	3-5/8	1-9/16	1-1/2	1-1/8	1.26
AN8983006302	63 x 25	6-7/8	4-3/8	2-1/2	5-3/16	3-5/8	1-9/16	1-1/2	1-7/16	1.15

Note: Requires hole saw bit to drill pipe. AN8983002502 (25 mm x 20 mm) use ANK0043. All others use ANK00143. ANK0243 also required.

Part No.	ØD x NPT (in)	A	A1	A2	B	B1	B2	C	S	Weight
AN8983002549	25 x 1/2	3-15/16	2-1/2	1-7/16	2-3/4	2-1/16	11/16	1-5/16	1-1/8	0.38
AN8983003204	32 x 1/2	4-7/16	2-3/4	1-11/16	3-3/16	2-5/16	7/8	1-5/16	1-1/8	0.40
AN8983004049	40 x 1/2	5-1/8	3-1/4	1-7/8	3-15/16	2-7/8	1-1/16	1-15/16	1-1/8	0.70
AN8983004069	40 x 3/4	5-1/8	3-1/4	1-7/8	3-15/16	2-7/8	1-1/16	1-15/16	1-1/8	0.71
AN8983005049	50 x 1/2	5-1/8	3-7/16	2-3/16	4-7/16	3-3/16	1-1/4	1-13/16	1-7/16	0.77
AN8983005069	50 x 3/4	5-1/8	3-7/16	2-3/16	4-7/16	3-3/16	1-1/4	1-13/16	1-7/16	0.74
AN8983006349	63 x 1/2	6-1/2	3-15/16	2-1/2	5-3/16	3-5/8	1-9/16	2-5/16	1-7/16	1.14
AN8983006369	63 x 3/4	6-1/2	3-15/16	2-1/2	5-3/16	3-5/8	1-9/16	2-5/16	1-7/16	1.11

Quick reducing brackets with NPT female connections do not have SmartPipe+ fittings.



Quick reducing bracket



Quick reducing bracket NPT connection

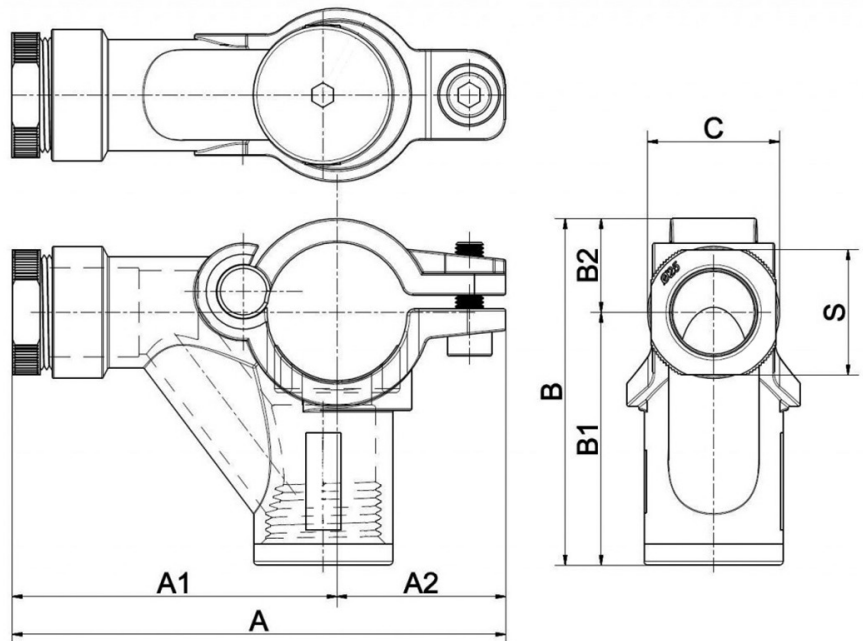

Dimensions in inches (in.) and weight in pounds (lbs.) unless otherwise noted. For larger piping and fittings, see SmartPipeXL. For installation instructions, see SmartPipe+ Service Manual. **Specifications subject to change without notice.**

45° Threaded Wall Brackets



Part No.	ØD x NPT (mm x in.)	Fig.	A	B	F	G	M	Wt.
AN8984102504	25 x 1/2	1	3-7/8	3-1/8	1/4	15/16	3-1/4	0.35
AN8984202504	25 x 1/2 x 1/2	2						0.39

Note: Wall bracket requires an additional 25 mm fitting or 25 mm ball valve in order to connect to the pipe. Can use 20 x 25 mm ball valve (AN8988102520) to connect 20 mm pipe or a 25 mm fitting and a 25 x 20 plug-in reducer (AN8202502502).

Fig. 1

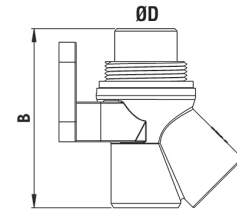
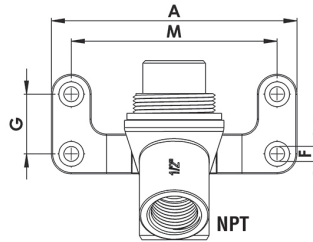
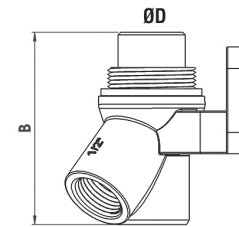
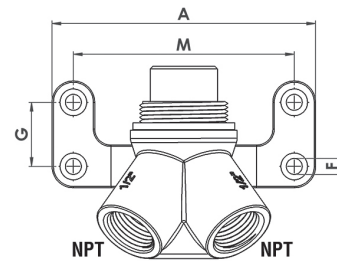

Fig. 2



45° Wall Bracket with Ball Valve

Part No.	ØD x NPT (mm x in.)	Fig.	Ports	Wt.
AN8988502005	20 x 1/2	1	1 port	0.8
AN8988602004	20 x 1/2 x 1/2	2	2 port	0.9
AN8988502505	25 x 1/2	1	1 port	1.15
AN8988602504	25 x 1/2 x 1/2	2	2 port	1.2



Dimensions in inches (in.) and weight in pounds (lbs.) unless otherwise noted. For 3" through 8" piping and fittings, see SmartPipeXL. For installation instructions, see SmartPipe+ Service Manual. **Specifications subject to change without notice.**

Ball Valve (Female Thread to Female Thread)



Part No.	NPT (in.)	A	B	B1	E	G	Weight
AN8988304949	1/2	5-1/16	2-9/16	1-3/4	1-5/16	2-5/8	0.34
AN8988306969	3/4	5-3/16	2-3/4	1-7/8	1-9/16	3-1/16	0.92
AN8988308989	1	5-11/16	3-1/2	2-1/2	1-15/16	3-7/16	0.66
AN8988310909	1-1/4	8-1/8	4-3/8	3-1/8	2-3/8	4-9/16	1.28
AN8988312929	1-1/2	8-5/8	4-3/4	3-1/4	2-13/16	5-7/16	1.88
AN8988316969	2	10-11/16	5-3/4	3-7/8	3-1/2	6-11/16	2.92

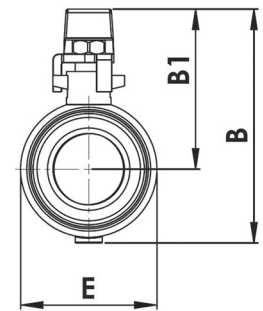
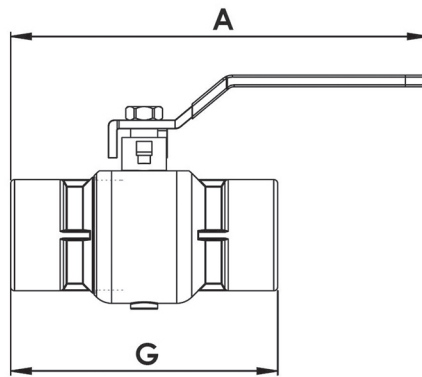

Ball Valve (Male Thread to Female Thread)



Part No.	NPT (in.)	A	B	B1	E	G	Weight
AN8988404949	1/2	5-1/16	2-9/16	1-3/4	1-5/16	2-5/8	0.32
AN8988406969	3/4	5-3/16	2-3/4	1-7/8	1-9/16	3-1/8	0.44
AN8988408989	1	5-11/16	3-1/2	2-1/2	1-15/16	3-9/16	0.74
AN8988410909	1-1/4	8-1/8	4-3/8	3-1/8	2-3/8	4-1/2	1.32
AN8988412929	1-1/2	8-5/8	4-3/4	3-1/4	2-13/16	4-7/8	1.72
AN8988416969	2	10-11/16	5-3/4	3-7/8	3-1/2	6-1/2	3.02

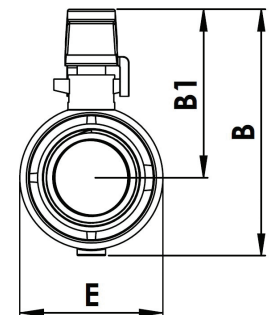
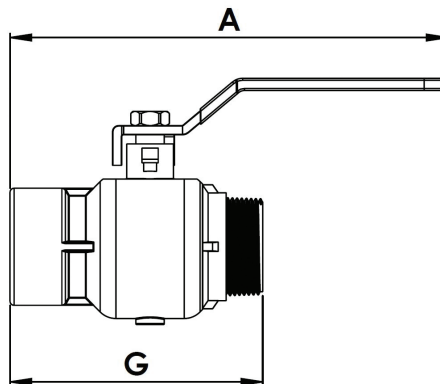

Dimensions in inches (in.) and weight in pounds (lbs.) unless otherwise noted. For larger piping and fittings, see SmartPipeXL. For installation instructions, see SmartPipe+ Service Manual. **Specifications subject to change without notice.**

Ball Valve (Pipe to Pipe)

Part No.	ØD (mm)	A	B1	B	E	G	L	S	Weight
AN8988102002	20	5-3/16	2-7/8	4-1/4	1-9/16	3-7/8	1-3/8	1-1/8	0.5
AN8988102520	20 x 25	5-3/16	2-7/8	4-1/4	1-9/16	4	1-7/16	1-7/16	0.85
AN8988102502	25	5-15/16	3-7/16	4-13/16	2	4-3/8	1-7/16	1-7/16	0.55
AN8988103203	32	8	4-3/8	3-1/8	2-3/8	5-3/8	1-13/16	1-11/16	1.46
AN8988104004	40	5-3/8	4-3/4	6-7/8	2-13/16	6-5/8	2-1/4	2-1/16	2.1
AN8988105005	50	11-1/8	6-1/8	9-1/4	3-1/2	7-7/8	2-11/16	2-5/8	3.66
AN8988106306	63	12-1/16	6-15/16	9-13/16	4-5/16	10	3-1/4	3-1/4	6.28

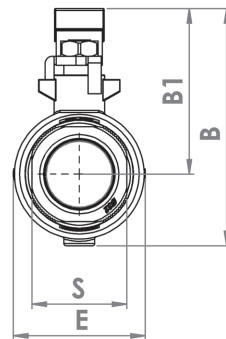
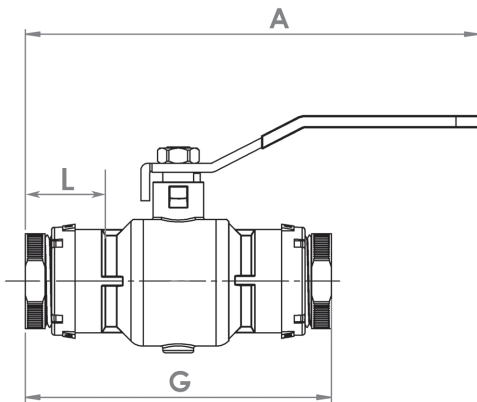

Ball Valve (Pipe to Thread)

Part No.	ØD x NPT (mm x in.)	A	B1	B	E	G	L	S	Weight
AN8988202004	20 x 1/2	5-3/16	2-7/8	4-1/4	1-9/16	3-11/16	1-3/8	1-1/8	0.45
AN8988202506	25 x 3/4	5-15/16	3-7/16	4-13/16	2	4-1/8	1-7/16	1-7/16	0.8
AN8988203208	32 x 1	8	4-3/8	3-1/8	2-3/8	5-3/16	1-13/16	1-11/16	1.32
AN8988204010	40 x 1-1/4	8	4-3/8	6-11/16	2-3/8	5-3/16	1-13/16	1-11/16	1.9
AN8988205012	50 x 1-1/2	8-3/8	4-3/4	6-7/8	2-13/16	5-3/4	2-1/4	2-1/16	3.26
AN8988206316	63 x 2	11-1/8	6-1/8	9-1/4	3-1/2	7-3/8	2-11/16	2-5/8	5.18

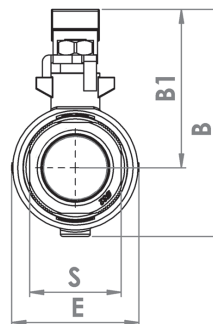
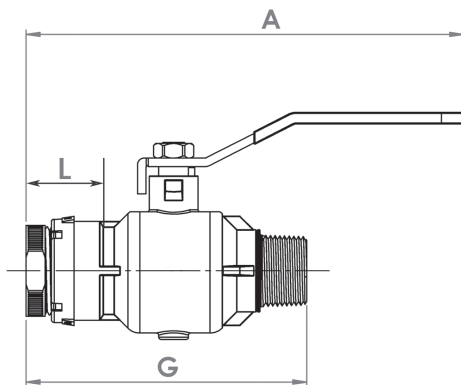

Dimensions in inches (in.) and weight in pounds (lbs.) unless otherwise noted. For larger piping and fittings, see SmartPipeXL. For installation instructions, see SmartPipe+ Service Manual. **Specifications subject to change without notice.**

Hose (Pipe to Pipe)



Use part number AN66989903, anti-whiplash strap. Refer to installation information for proper bend radius and proper installation practices. Requires additional SmartPipe+ fittings to install.

Part No.	ØD (mm)	L	MATL 1	MATL 2	A	Weight
AN8992002010	20	11-13/16	Aluminum	Rubber	15-1/4	0.95
AN8992002011	20	39-3/8			42-13/16	1.95
AN8992002510	25	11-13/16			15-1/2	1.4
AN8992002511	25	39-3/8			43-1/16	2.78
AN8992003210	32	11-13/16			16-7/16	2.16
AN8992003211	32	39-3/8			44	4.01
AN8992004010	40	19-11/16			25-3/16	3.37
AN8992004011	40	39-3/8			44-7/8	5.0
AN8992005010	50	19-11/16			26	5.3
AN8992005011	50	59			66-11/16	5.7
AN8992006310	63	19-11/16			27-3/16	8.5
AN8992006311	63	59			66-11/16	11.2

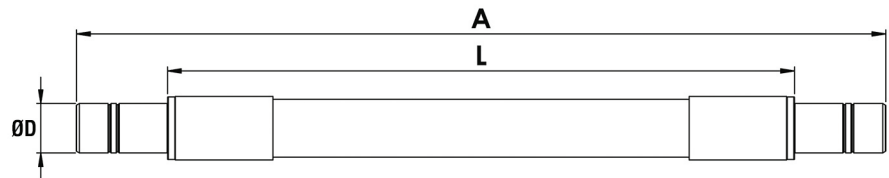

Vented End Cap



Part No.	ØD (mm)	A	B	C	S	Weight
AN89865020	20	1-7/8	13/16	7/8	11/16	0.08
AN89865025	25	2-1/4	1	1-1/8		0.10
AN89865032	32	2-9/16	1-1/4	1-3/8		0.13
AN89865040	40	2-13/16	1-9/16	1-3/4		0.20
AN89865050	50	3-1/4	2	2-3/16		0.36
AN89865063	63	3-7/8	2-1/2	2-13/16		0.64

Note: Will require separate SmartPipe+ fitting

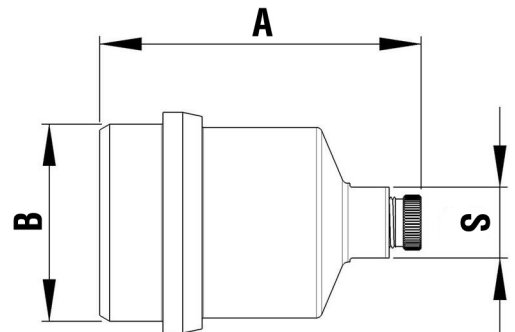
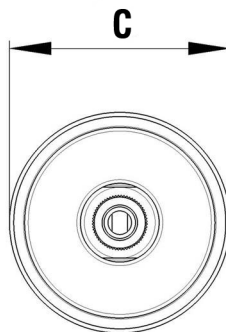

Dimensions in inches (in.) and weight in pounds (lbs.) unless otherwise noted. For larger piping and fittings, see SmartPipeXL. For installation instructions, see SmartPipe+ Service Manual. **Specifications subject to change without notice.**

Anti-whiplash Strap

Part No.	Weight
AN66989903	0.47

Prevents whiplash should SmartPipe+ flexible hose be disconnected while under pressure. Conforms to ISO 4414 safety standard. See installation information for proper installation practices.



Lockable Handle

Part No.	ØD (mm)	Weight
AN89888020	20	0.10
AN89888025	25	0.15
AN89888032	32	0.25
AN89888040	40	0.25
AN89888050	50	0.44
AN89888063	63	0.52



Pipe Marking Tool

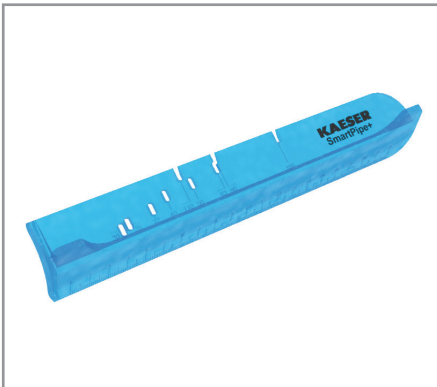

Part No.	L	A	B	C	Weight
AN89531001	8-7/8	1-3/8	1-7/16	1-9/16	0.09

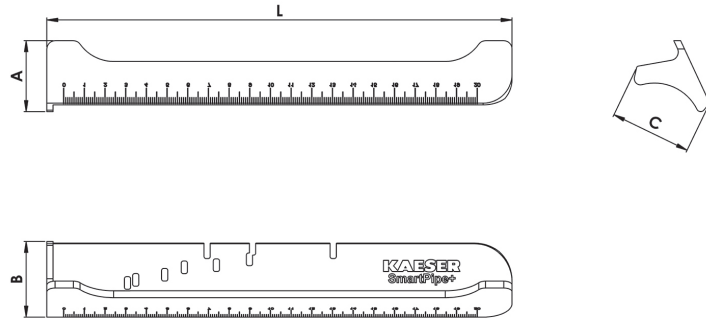

Pipe Cutter

Part No.	L	H	Weight
ANK0040	10-1/16	3-7/8	1.94

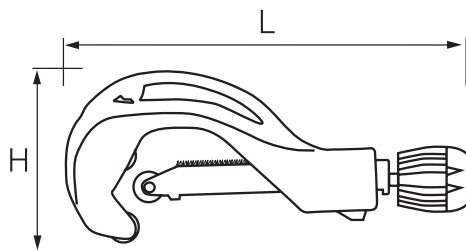

ANK0040, 20 mm - 63 mm (3/4" to 2 1/2") Pipe Cutter, uses replacement blades ANK0240.

Dimensions in inches (in.) and weight in pounds (lbs.) unless otherwise noted. For larger piping and fittings, see SmartPipeXL. For installation instructions, see SmartPipe+ Service Manual. **Specifications subject to change without notice.**

Hole Saw Bits

Part No.	Description	Weight
ANK0043	14 mm Hole Saw Bit	0.04
ANK0143	19 mm Hole Saw Bit	0.30
ANK0342	24 mm Hole Saw Bit (includes Arbor and Pilot)	0.34
ANK0243	Drill Arbor and Pilot Bit (14 mm to 25 mm)	0.20



Drill arbor and pilot bit



Hole saw bits

Deburrer and Chamfer Tools

Part No.	Fig.	Description	Weight
ANK0141	1	20 mm - 50 mm (3/4" to 2") Pipe Deburrer	1.27
AN113835	2	20 mm - 50 mm Manual/Electric Pipe Deburrer	1.00
ANK0042	3	Hole Deburrer	0.08
AN292110	4	63 mm (2-1/2") Chamfer Tool	1.38



Fig. 1



Fig. 2



Fig. 3



Fig. 4 Uses replacement blade AN292011

Dimensions in inches (in.) and weight in pounds (lbs.) unless otherwise noted. For larger piping and fittings, see SmartPipeXL. For installation instructions, see SmartPipe+ Service Manual. **Specifications subject to change without notice.**

Composite Quick-Connect Couplers and Plugs

SmartPipe couplers are designed for easy one-handed connection and disconnection. To connect, simply press the plug into the coupler port. To disconnect, pull the coupler sleeve to release the plug.

Pressure Loss in Couplers

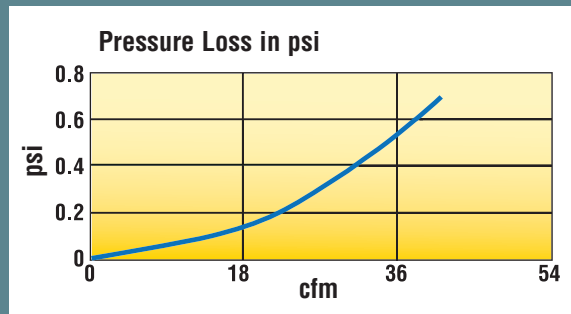

Cv rating = 1.24

Universal Coupler (ISO 6150B/Automotive)

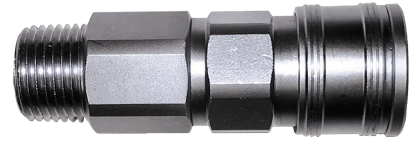

Part No.	Nipple	NPT
ANK1484	1/4"	1/2"
ANK3884	3/8"	1/2"

Accessories

Industrial Nipples (ISO B)

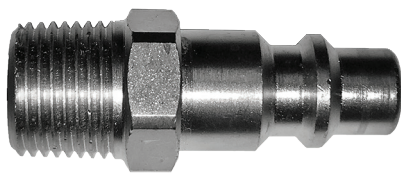

Part No.	Nipple	NPT
ANK4184	1/4"	1/4"
ANK8184	3/8"	3/8"

Automotive Nipples

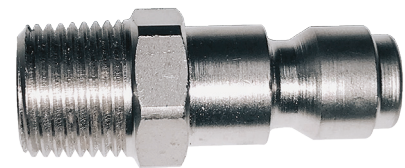

Part No.	Nipple	NPT
ANK4284	1/4"	1/4"
ANK8284	3/8"	3/8"

The World Is Our Home

As one of the world's largest compressed air systems providers and compressor manufacturers, KAESER COMPRESSORS is represented throughout the world by a comprehensive network of branches, subsidiary companies and factory trained partners.

With innovative products and services, KAESER COMPRESSORS' experienced consultants and engineers help customers to enhance their competitive edge by working in close partnership to develop progressive system concepts that continuously push the boundaries of performance and compressed air efficiency. Every KAESER customer benefits from the decades of knowledge and experience gained from hundreds of thousands of installations worldwide and over ten thousand formal compressed air system audits.

These advantages, coupled with KAESER's worldwide service organization, ensure that our compressed air products and systems deliver superior performance with maximum uptime.



More Compressed Air for Less Energy.



KAESER Boisbriand, QC
3760 La Verendrye Street
Boisbriand, QC J7H 1R5
Telephone: (450) 971-1414
Toll free: (800) 477-1416
info.canada@kaeser.com

KAESER Surrey, BC
3757 190th Street
Surrey, BC V3Z 0P6
Telephone: (604) 516-7821
Toll Free: (800) 477-1416
info.canada@kaeser.com

KAESER Lévis, QC
103-1194 ch. Industriel
Lévis, QC G7A 1B1
Telephone: (450) 971-1414
Toll free: (800) 477-1416
info.canada@kaeser.com

KAESER London, ON
185 Exeter Rd Unit B,
London, ON N6L 1A4
Telephone: (226) 721-0070
Toll free: (800) 477-1416
info.canada@kaeser.com

www.kaeser.com